

F226S

Published:12/21/2017

TABLE OF CONTENTS

CYLINDER, CRANKCASE, PISTON	1
FANCOVER, CYLINDER COVER	3
MAGNETO.....	5
AIR CLEANER	7
FUEL TANK	9
MUFFLER	11
RECOIL STARTER.....	13
MAIN PIPE	15
THROTTLE LEVER	17
SHIELD	19
NYLON LINE CUTTER.....	21
ACCESSORIES	23
CARBURETOR.....	25

CYLINDER, CRANKCASE, PISTON

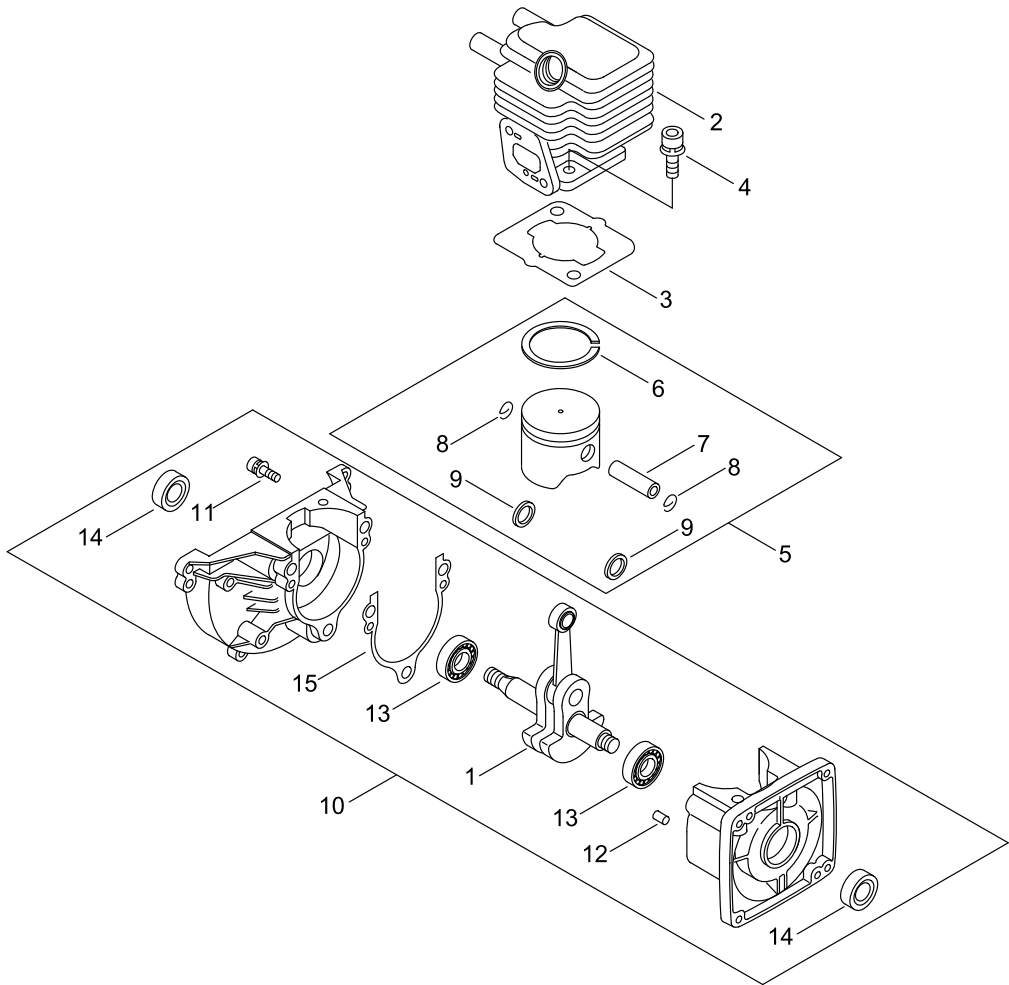

CYLINDER, CRANKCASE, PISTON

KEY NO	LV(+)	Part No	Description	Qty	Standard	Comment
1		A011-000101	CRANKSHAFT,ASM	1		
2		A130-002100	CYLINDER	1		
3		101010-44332	GASKET, CYL. BASE	1		
4		900162-05022	BOLT, H.S. 5*22	2	5*22 W,SW	
5		P021-007712	PISTON KIT	1		
6	+	A101-000090	RING,PISTON	1		
7	+	100013-11520	PIN, PISTON	1		
8	+	100015-04630	CIRCLIP, PISTON PIN	2		
9	+	100014-11520	SPACER, PISTON PIN	2		
10		100204-52133	CRANKCASE KIT	1		
11	+	900162-05028	BOLT, H.S. 5*28	3	5*28 W,SW	
12	+	100215-03930	PIN, DOWEL	2		
13	+	94095-36201	BEARING BALL	2		
14	+	100212-42031	OILSEAL	2	ISCD 12*22*4.5	
15	+	100242-42030	GASKET, CRANKCASE	1		

FANCOVER, CYLINDER COVER

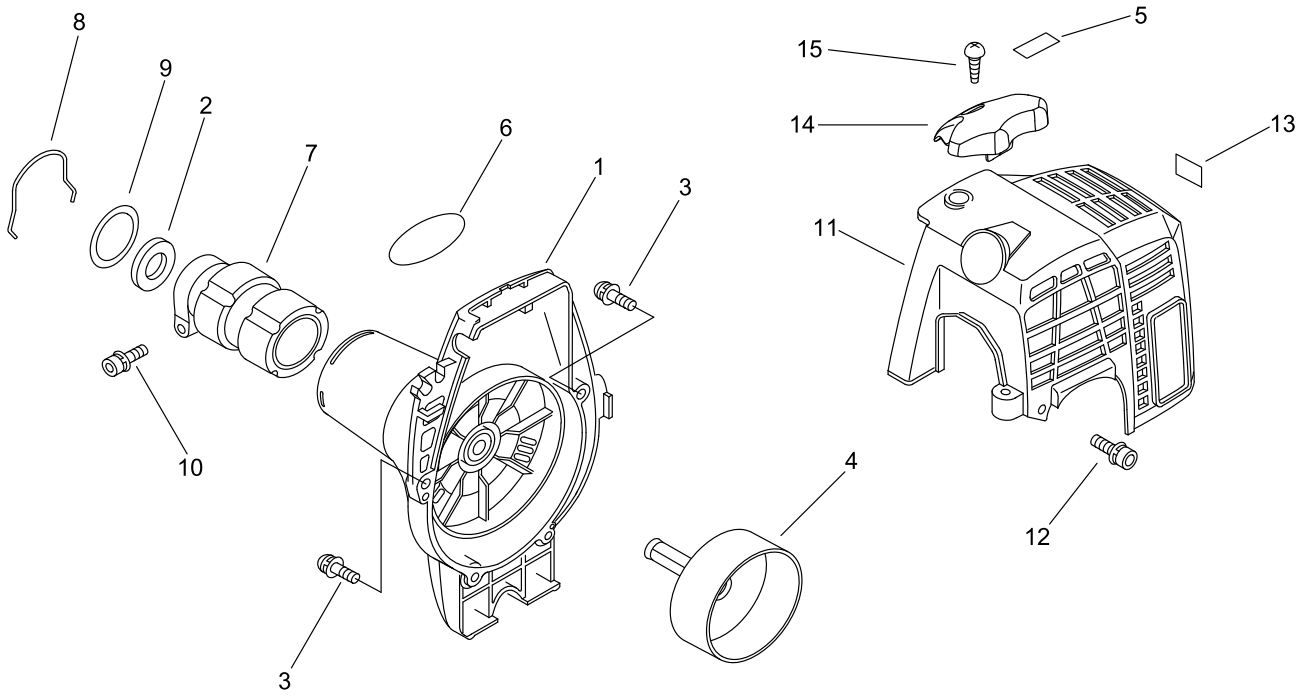

FANCOVER, CYLINDER COVER

KEY NO	LV(+)	Part No	Description	Qty	Standard	Comment
1		A172-001810	COVER,FAN	1		
2		175313-20430	RING, FELT	1		
3		91363-04016	SCREW	3	SMB-4*16/W, SW	
4		175005-44331	DRUM, CLUTCH	1		
5		X530-000290	LABEL,EYE CATCHER	1		
6		X543-003870	LABEL,MODEL	1		
7		610922-55931	HOLDER, MAIN PIPE	1		
8		660316-55630	CLIP	1		
9		V315-000030	WASHER,CIRCULAR 30	1	33.5*41.0*T0.5	
10		91118-05028	BOLT	1	CM-5*28	
11		A160-002340	COVER,CYLINDER	1		
12		V202-000090	BOLT,4	2	4*16	
13		X505-002310	LABEL,CAUTION	1	HOT CAUTION	
14		A162-000130	GUARD, TOP	1		
15		900253-05020	SCREW 5*20	1	5*20	

MAGNETO

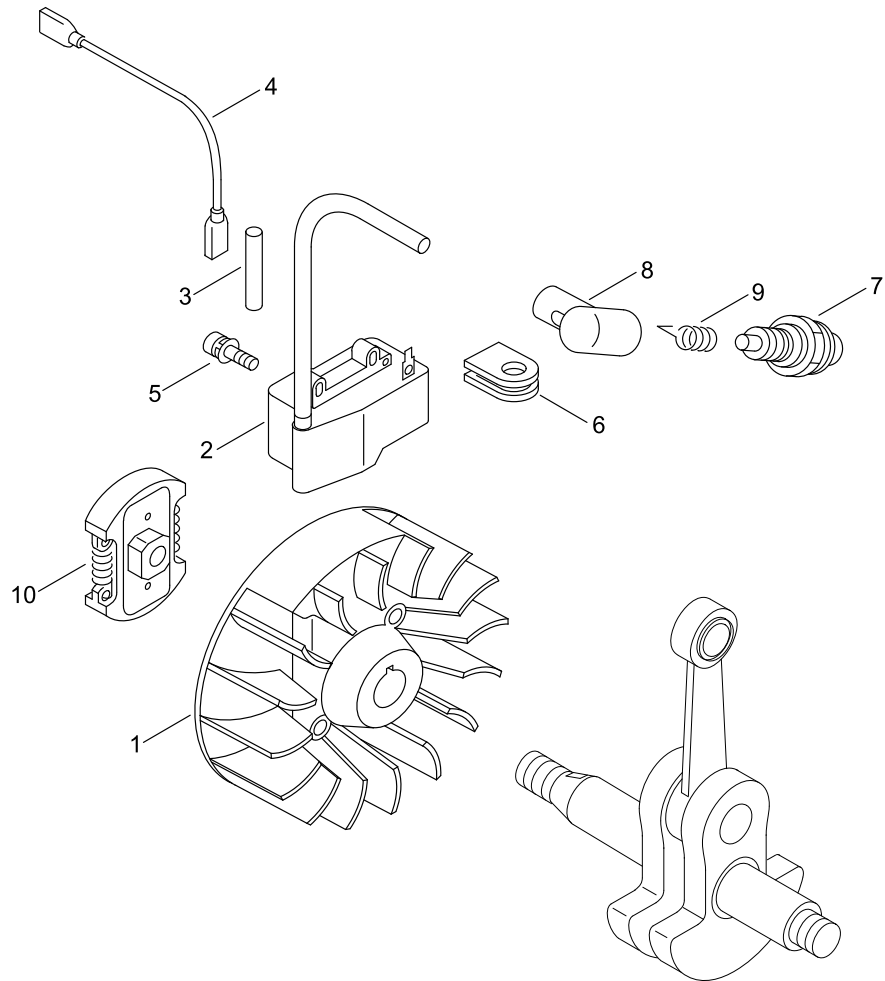

MAGNETO

KEY NO	LV(+)	Part No	Description	Qty	Standard	Comment
1		A409-000160	ROTOR,MAGNETO	1		
2		A411-000140	COIL,IGNITION	1		
3		V475-007300	TUBE	1		
4		162010-52830	LEAD, GROUND	1		
5		900162-04020	BOLT, H.S. 4*20	2	4*20 W,SW	
6		156112-40630	GROMMET	1		
7		A425-000000	SPARKPLUG	1	BPMR8Y	
8		159012-03433	CAP, SPARK PLUG	1		
9		159011-03432	COIL, SPARK PLUG	1		
10		175000-56831	CLUTCH ASSEMBLY	1		

AIR CLEANER

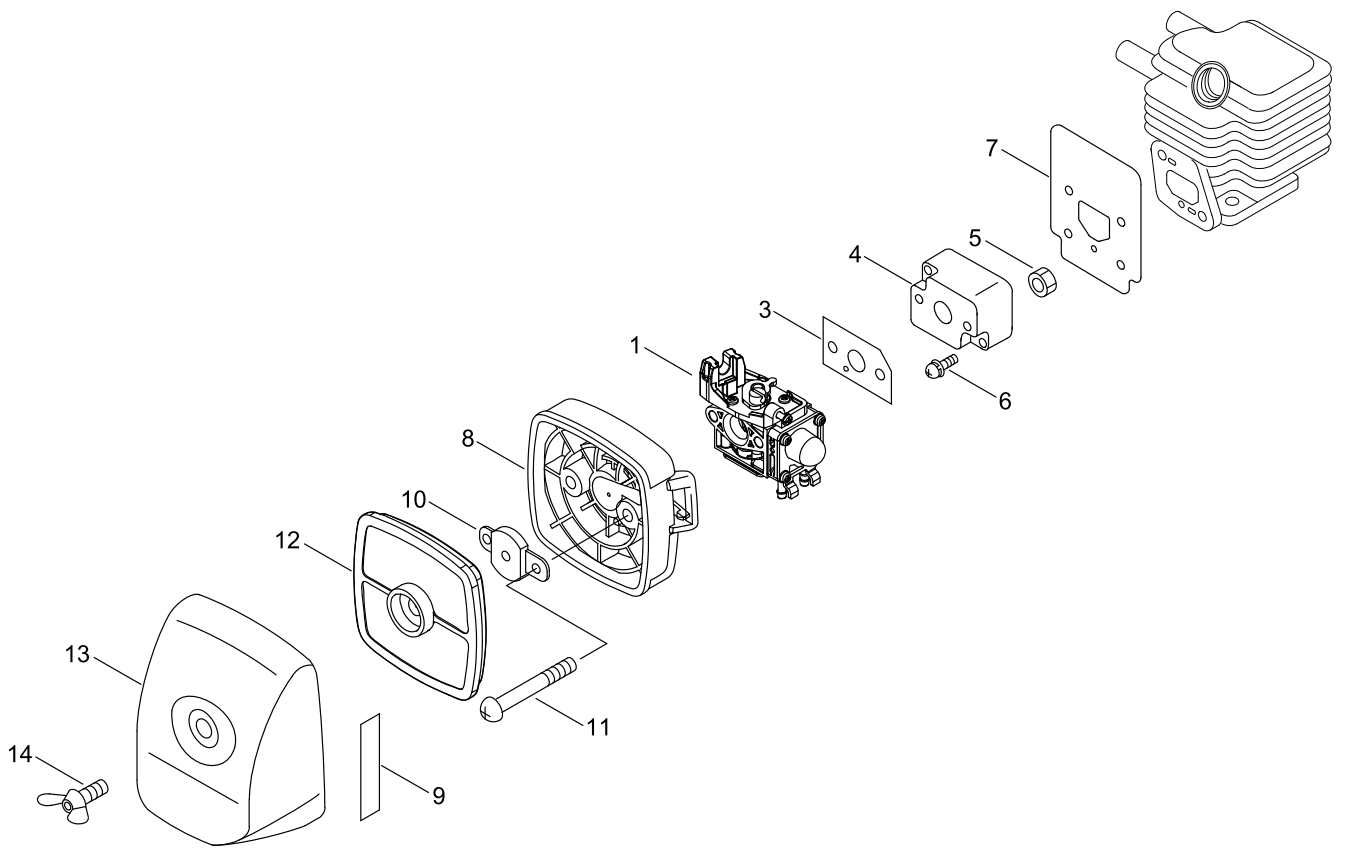

AIR CLEANER

KEY NO	LV(+)	Part No	Description	Qty	Standard	Comment
1		A021-003880	CARBURETOR, DIAPHRAGM	1	ZAMA RB-K113	
3		V103-001390	GASKET,INTAKE	1		
4		130017-44331	INSULATOR	1		
5		900500-00005	NUT 5	2	5	
6		900238-05022	SCREW 5*22	2	5*22	
7		V103-001640	GASKET,INTAKE	1		
8		P021-038590	CASE,CLEANER ASY	1		
9		890332-52730	LABEL, CHOKE	1		
10		129011-52730	PLATE, PREVENT	1		
11		900220-05065	SCREW 5*65	2	5*65	
12		A226-001410	ELEMENT,AIR FILTER	1		
13		130313-05863	LID, AIR CLEANER	1		
14		210417-52730	BOLT, WING	1	5*20	

FUEL TANK

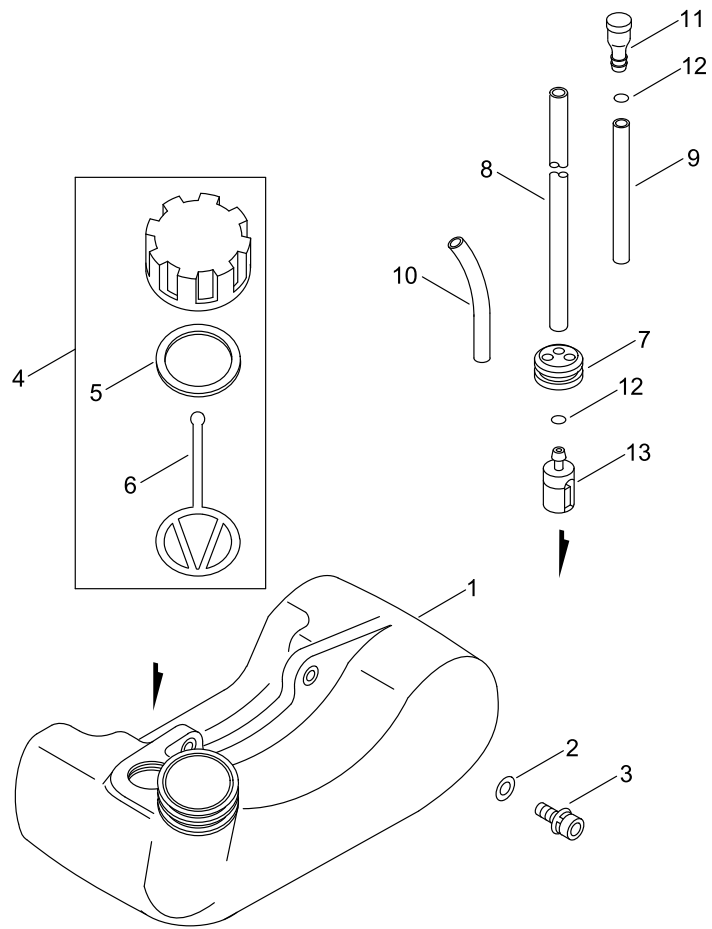

FUEL TANK

KEY NO	LV(+)	Part No	Description	Qty	Standard	Comment
1		A350-000480	TANK, FUEL	1		
2		900603-00005	WASHER 5	2	5.5*12*0.8	
3		91118-05020	BOLT	2	CM-5*20	
4		P021-035680	FUEL CAP ASY	1	T242	
5	+	131016-55830	GASKET, FUEL CAP	1		
6	+	A365-000060	CONNECTOR,CAP	1	L=123	
7		132115-46730	GROMMET, FUEL	1		
8		V471-001190	PIPE	1	3*5*180 NBR	
9		V471-001200	PIPE	1	3*5*70 NBR	
10		132012-56030	PIPE	1	3*6*80 YL	
11		A356-000031	VALVE,CHECK	1		
12		V490-001240	CLIP	2	6MM	
13		131205-07320	STRAINER, FUEL	1		

MUFFLER

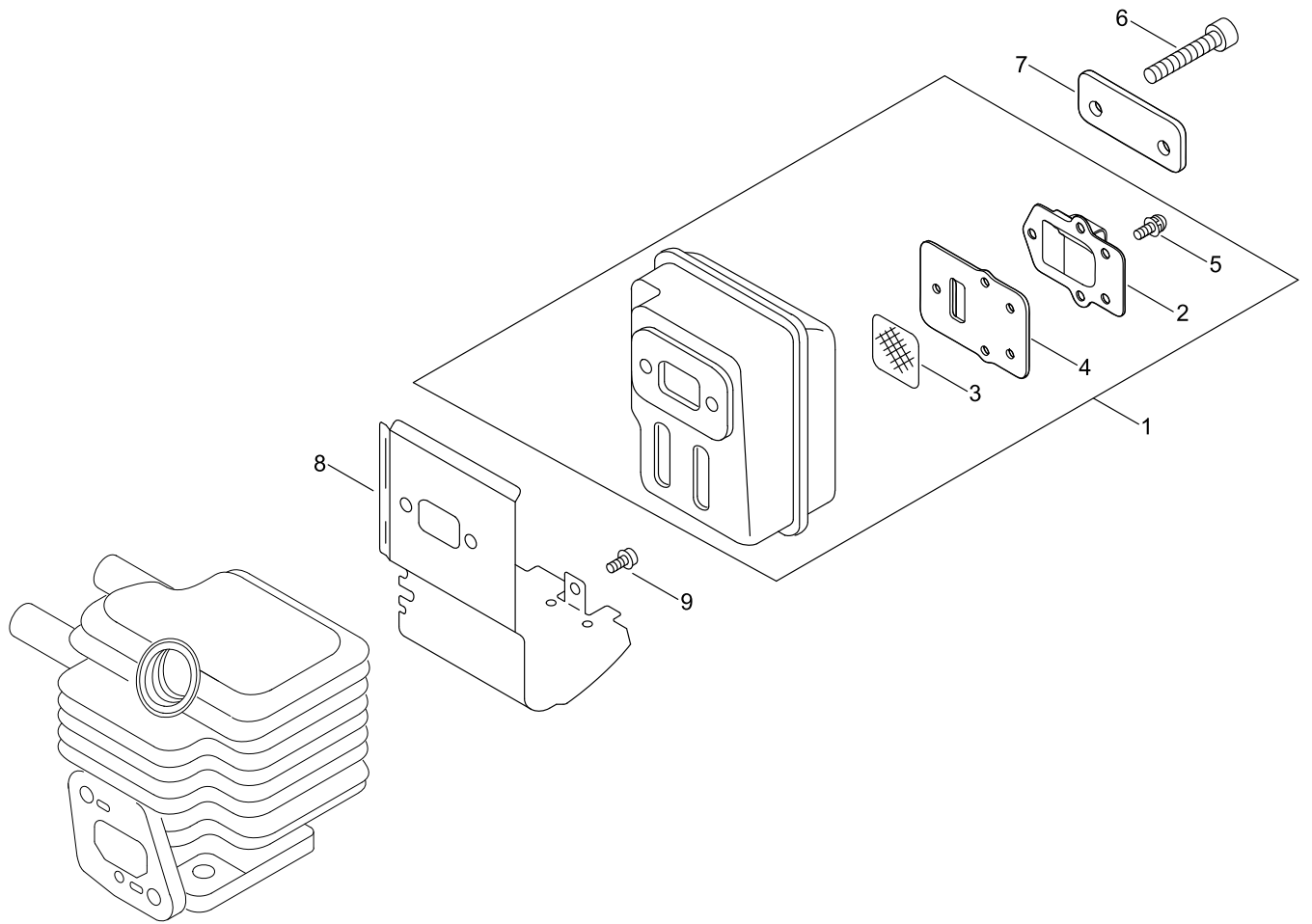

MUFFLER

KEY NO	LV(+)	Part No	Description	Qty	Standard	Comment
1		P021-016642	MUFFLER ASY	1		
2	+	A313-000600	GUIDE,EXH	1		
3	+	145862-40630	SCREEN, MUFFLER	1		
4	+	V104-001760	GASKET,EXHAUST	1		
5	+	91367-04010	SCREW	5	4*10/SW(SUS)	
6		900105-05055	BOLT, H.S. 5*55	2	5*55	
7		V150-000371	PLATE,EYE	1		
8		V104-000500	GASKET,EXHAUST	1		
9		91121-04008	BOLT, FLANGE	1	M4*8 10.9	

RECOIL STARTER

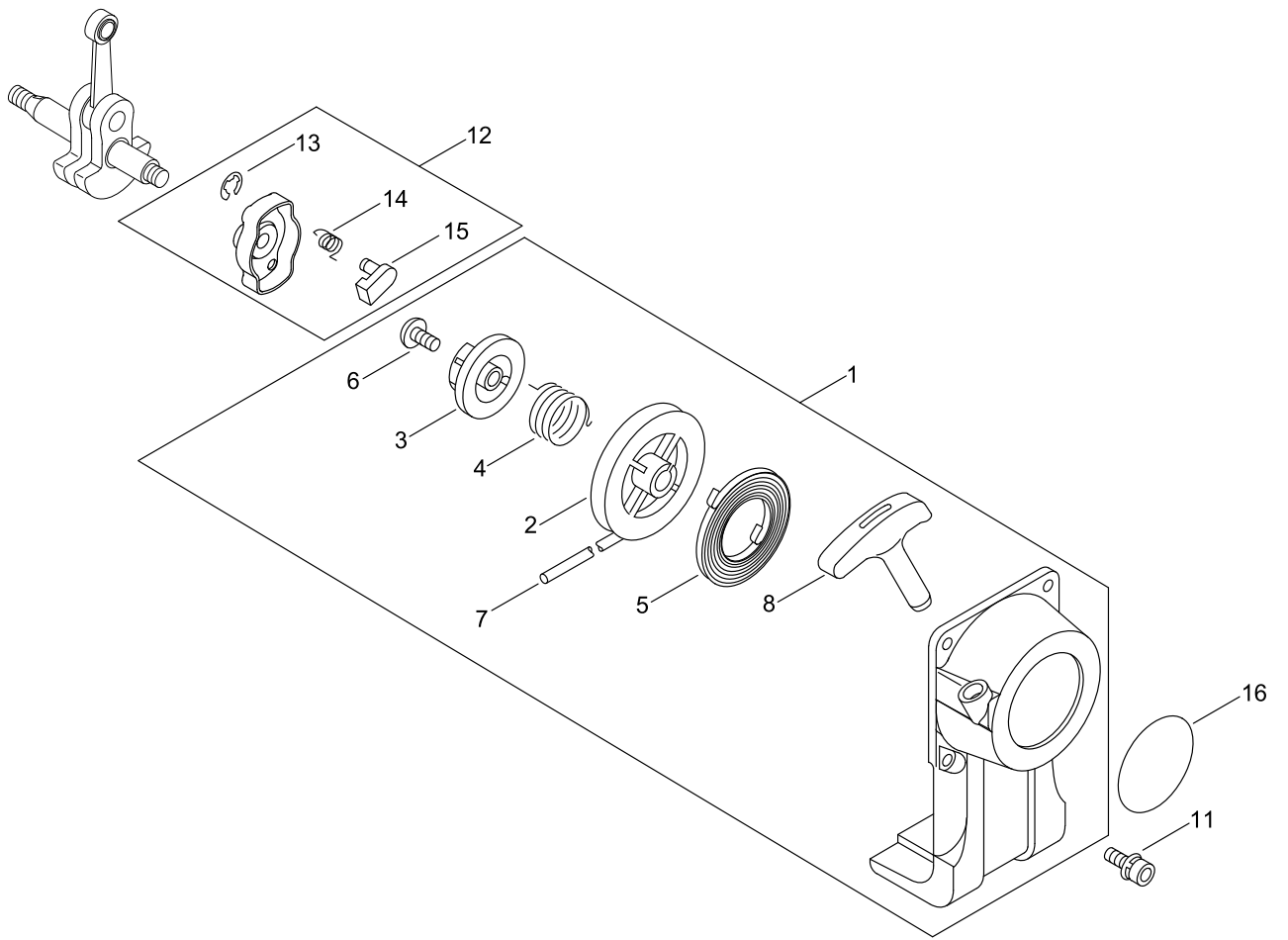

RECOIL STARTER

KEY NO	LV(+)	Part No	Description	Qty	Standard	Comment
1		A051-001401	STARTER,RECOIL ASY	1		
2	+	P022-034040	DRUM, STARTER	1		
3	+	P022-034030	PLATE, CAM	1		
4	+	P022-008270	SPRING,DAMPER	1		
5	+	P022-019680	SPRING, SPIRAL	1		
6	+	177236-61830	SCREW	1		
7	+	P022-025730	ROPE, STARTER	1		
8	+	P022-023170	GRIP, STARTER	1		
11		V202-000090	BOLT,4	2	4*16	
12		A052-000180	PULLEY,ASM STARTER	1		
13	+	P022-002100	E-RING	2	4	
14	+	P022-006510	SPRING, RETURN	2		
15	+	P022-006850	PAWL, STARTER	2		
16		X543-003880	LABEL,MODEL	1		

MAIN PIPE

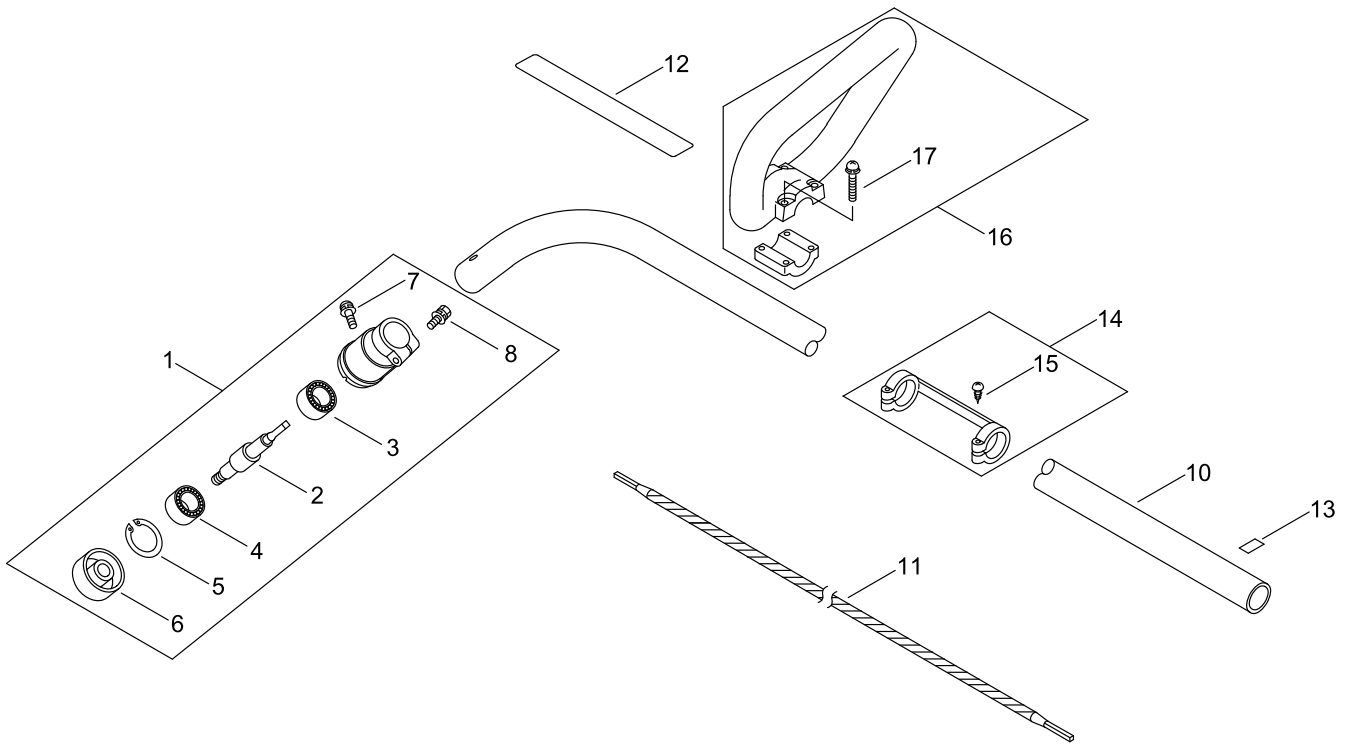

MAIN PIPE

KEY NO	LV(+)	Part No	Description	Qty	Standard	Comment
1		P021-009461	CASE,ASM BEARING	1		
2	+	C534-000341	SHAFT,GEAR	1		
3	+	94060-06200	BEARING BALL	1	WEAPON BB6200	
4	+	94061-06200	BEARING, BALL	1	BB6200 LU,DU	
5	+	900702-00030	CIRCLIP 30	1	CR-30	
6	+	C535-000340	FIXTURE, BLADE	1	3/8-24UNF	
7	+	900242-04010	SCREW 4*10	1	4*10	
8	+	91118-05025	BOLT	1	CM-5*25	
10		C050-000470	PIPE,MAIN	1		
11		C506-000320	SHAFT, FLEXIBLE	1	3263-002A	
12		X505-000140	LABEL,CAUTION	1		
13		890152-04930	LABEL, CAUTION	1		
14		610281-54131	COLLER	1		
15	+	900253-04025	SCREW 4*25	2	4*25	
16		P021-016090	FRONT HANDLE ASY	1		
17	+	900242-05035	SCREW 5*35	4	5*35	

THROTTLE LEVER

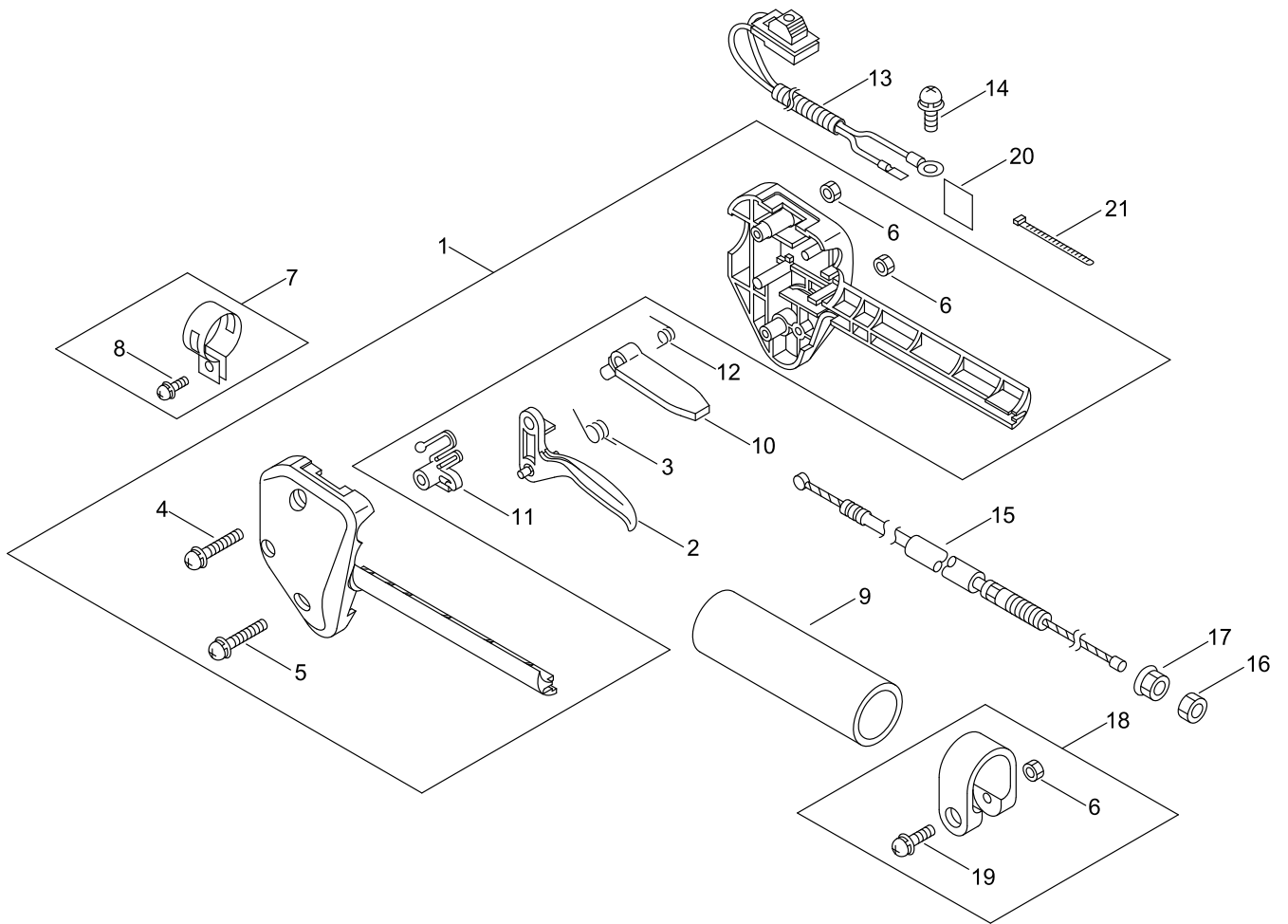

THROTTLE LEVER

KEY NO	LV(+)	Part No	Description	Qty	Standard	Comment
1		178003-52130	BRACKET SET, THROTTLE	1		
4	+	900242-05035	SCREW 5*35	1	5*35	
5	+	900242-05025	SCREW 5*25	1	5*25	
6	+	900500-00005	NUT 5	2	5	
2		C450-000700	TRIGGER,THROTTLE	1		
3		178043-42230	SPRING, THR. RETURN	1		
7		301200-29430	BAND ASSY	1		
8	+	900242-05014	SCREW 5*14	1	5*14	
9		C403-000140	GRIP, HANDLE	1	L129.5*28	
10		C460-000370	LOCKOUT,THROTTLE	1		
11		178012-52630	LOCKOUT, THROTTLE	1		
12		178013-52630	SPRING, THR. LOCK	1		
13		A440-001871	SWITCH, ON OFF	1		
14		91363-04016	SCREW	1	SMB-4*16/W, SW	
15		V430-002290	CABLE,BOWDEN	1	330+61	
16		900502-00006	NUT 6 (3N)	1	3N6	
17		900518-00006	NUT, FLANGE	1	6	
18		P021-014550	BAND 25	1		
19	+	900242-05028	SCREW 5*28	1	5*28	
6	+	900500-00005	NUT 5	1	5	
20		890157-39130	LABEL, SWITCH	1		
21		V495-002690	BAND	2	CV-100	

SHIELD

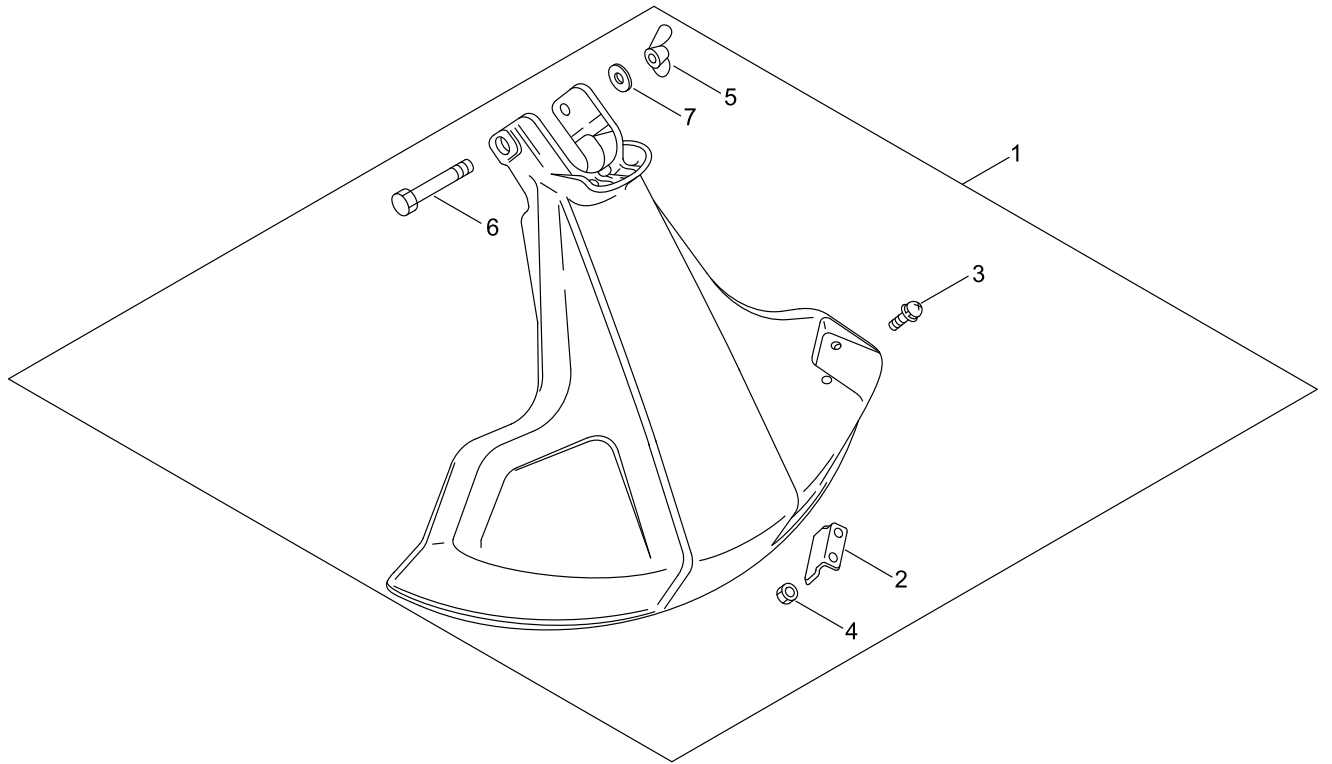

SHIELD

KEY NO	LV(+)	Part No	Description	Qty	Standard	Comment
1		P021-009552	SHIELD KIT	1		
2	+	C554-000021	KNIFE, CORD	1		
3	+	900238-05012	SCREW 5*12	2	5*12	
4	+	900500-00005	NUT 5	2	5	
5	+	900033-00008	NUT, WING 1/4-20	1	1/4-20	
6	+	900017-08064	BOLT 1/4-20*2A	1	1/4-20*2A	
7	+	910300-27700	WASHER,CIRCULAR 6	1		

NYLON LINE CUTTER

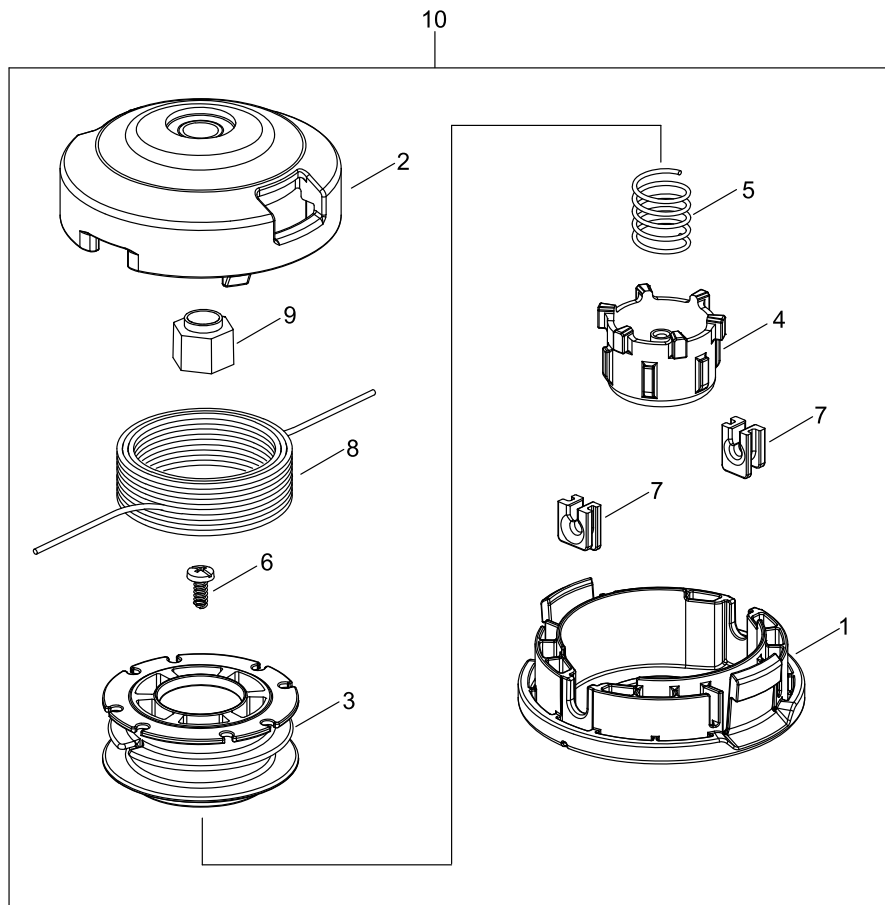

NYLON LINE CUTTER

KEY NO	LV(+)	Part No	Description	Qty	Standard	Comment
10		X047-000450	CUTTER,ASM LINE	1	G137	
1	+	P022-025530	CASE	1		
2	+	P022-025630	COVER	1		
3	+	P022-025640	REEL	1		
4	+	P022-025560	BUTTON	1		
5	+	P022-025570	RETURN SPRING	1		
6	+	P022-025580	SET SCREW	1		
7	+	P022-025590	CORD GUIDE	2		
8	+	P022-025600	NYLON CORD	1		
9	+	P022-025660	SHAFT	1		

ACCESSORIES

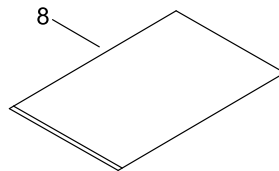
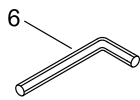
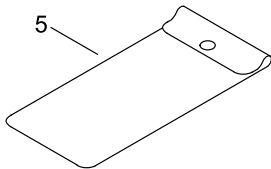
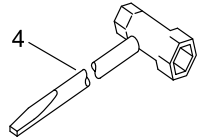
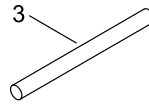
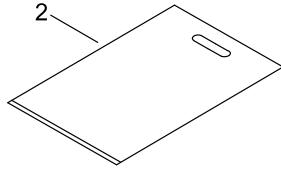
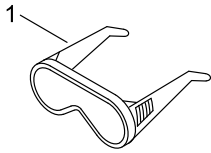

ACCESSORIES

KEY NO	LV(+)	Part No	Description	Qty	Standard	Comment
1		X690-000030	GOGGLE	1		
2		X698-000040	TOOL,CASE	1	400*500	
3		X606-000080	TOOL,BAR	1	5*120	
4		895410-02830	WRENCH, W/S. DRIVER	1		
5		898510-07130	BAG, TOOL	1		
6		X605-000100	TOOL,L WRENCH	1	4MM M5	
8		X772-000840	MANUAL,OPERATOR	1		

CARBURETOR

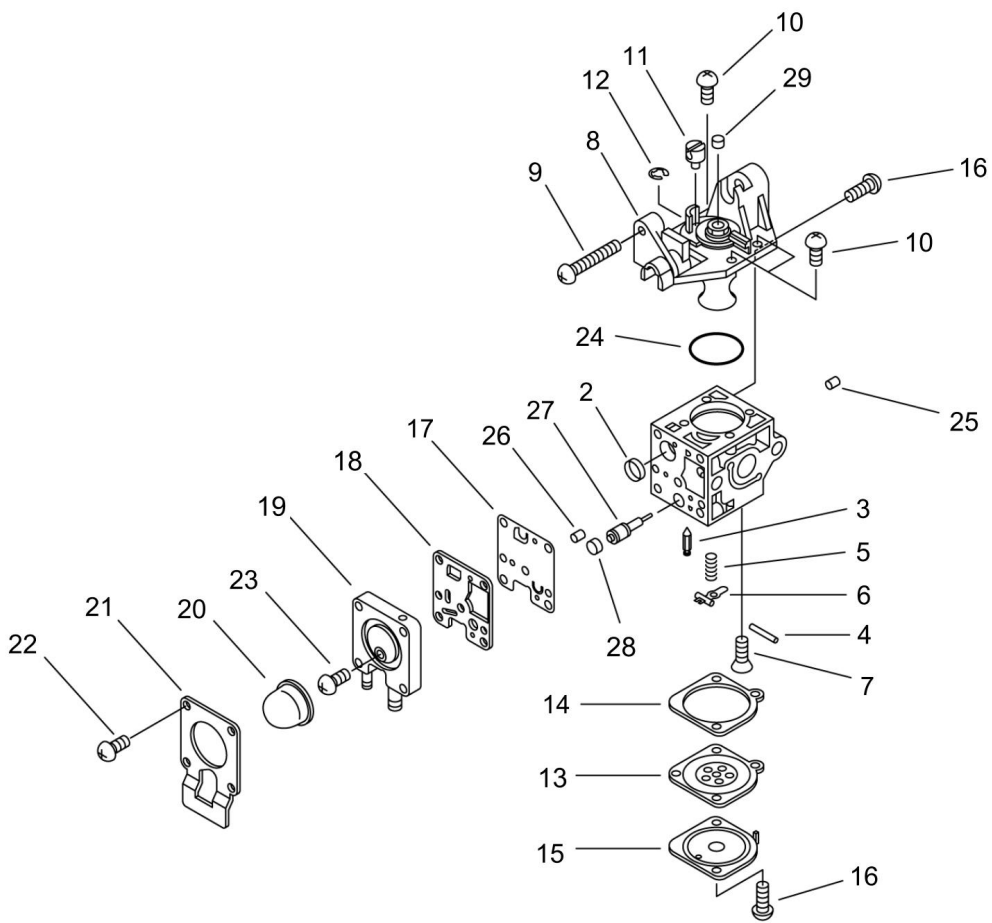

CARBURETOR

KEY NO	LV(+)	Part No	Description	Qty	Standard	Comment
		A021-003880	CARBURETOR, DIAPHRAGM	1	ZAMA RB-K113	
2	+	P005-000010	STRAINER	1		
3	+	125337-08260	VALVE, INLET NEEDLE	1		
4	+	125338-13930	PIN, METERING ARM	1		
5	+	P005-002430	SPRING, MET. LEVER	1		
6	+	125323-08260	ARM, VALVE	1		
7	+	125339-42030	SCREW	1		
8	+	P005-002460	COVER ASY, ROTOR	1		
9	+	P005-000100	SCREW, THROTTLEADJUST	1		
10	+	125344-13931	SCREW	3		
11	+	P005-001240	POST	1		
12	+	P005-000190	E-RING	1		
13	+	P005-002230	DIAPHRAGM ,METERING	1		
14	+	P005-000200	GASKET, METERING	1		
15	+	125342-52130	COVER, DIAPHRAGM	1		
16	+	125344-52130	SCREW	3		
17	+	P005-000510	DIAPHRAGM, PUMP	1		
18	+	P005-000520	GASKET, PUMP	1		
19	+	P005-001890	BASE, ASY PRIMER	1		
20	+	125381-46730	PUMP, PRIMING	1		
21	+	P005-000250	RETAINER	1		
22	+	P005-001900	SCREW	4		
23	+	P005-000270	SCREW	1		
24	+	P005-000280	O-RING	1		
25	+	P005-001000	ROLLER, GUIDE	1		
26	+	P005-001250	RETAINER,PLUG BALL	1		
27	+	P005-001260	SCREW,MAINN MIXTURE	1		
28	+	P005-001270	PLUG, H AJUST SCREW	1		
29	+	A259-000010	CAP,LIMITER	1		

NUMERICAL PARTS INDEX

Part No	Part description	Page	Part No	Part description	Page	Part No	Part description	Page
100013-11520	PIN, PISTON	2	895410-02830	WRENCH, W/S. DRIVER	24	A160-002340	COVER,CYLINDER	4
100014-11520	SPACER, PISTON PIN	2	898510-07130	BAG, TOOL	24	A162-000130	GUARD, TOP	4
100015-04630	CIRCLIP, PISTON PIN	2	900017-08064	BOLT 1/4-20*2A	20	A172-001810	COVER,FAN	4
100204-52133	CRANKCASE KIT	2	900033-00008	NUT, WING 1/4-20	20	A226-001410	ELEMENT,AIR FILTER	8
100212-42031	OILSEAL	2	900105-05055	BOLT, H.S. 5*55	12	A259-000010	CAP,LIMITER	26
100215-03930	PIN, DOWEL	2	900162-04020	BOLT, H.S. 4*20	6	A313-000600	GUIDE,EXH	12
100242-42030	GASKET, CRANKCASE	2	900162-05022	BOLT, H.S. 5*22	2	A350-000480	TANK, FUEL	10
101010-44332	GASKET, CYL. BASE	2	900162-05028	BOLT, H.S. 5*28	2	A356-000031	VALVE,CHECK	10
125323-08260	ARM, VALVE	26	900220-05065	SCREW 5*65	8	A365-000060	CONNECTOR,CAP	10
125337-08260	VALVE, INLET NEEDLE	26	900238-05012	SCREW 5*12	20	A409-000160	ROTOR,MAGNETO	6
125338-13930	PIN, METERING ARM	26	900238-05022	SCREW 5*22	8	A411-000140	COIL,IGNITION	6
125339-42030	SCREW	26	900242-04010	SCREW 4*10	16	A425-000000	SPARKPLUG	6
125342-52130	COVER, DIAPHRAGM	26	900242-05014	SCREW 5*14	18	A440-001871	SWITCH, ON OFF	18
125344-13931	SCREW	26	900242-05025	SCREW 5*25	18	C050-000470	PIPE,MAIN	16
125344-52130	SCREW	26	900242-05028	SCREW 5*28	18	C403-000140	GRIP, HANDLE	18
125381-46730	PUMP, PRIMING	26	900242-05035	SCREW 5*35	16	C450-000700	TRIGGER,THROTTLE	18
129011-52730	PLATE, PREVENT	8	900242-05035	SCREW 5*35	18	C460-000370	LOCKOUT,THROTTLE	18
130017-44331	INSULATOR	8	900253-04025	SCREW 4*25	16	C506-000320	SHAFT, FLEXIBLE	16
130313-05863	LID, AIR CLEANER	8	900253-05020	SCREW 5*20	4	C534-000341	SHAFT,GEAR	16
131016-55830	GASKET, FUEL CAP	10	900500-00005	NUT 5	8	C535-000340	FIXTURE, BLADE	16
131205-07320	STRAINER, FUEL	10	900500-00005	NUT 5	18	C554-000021	KNIFE, CORD	20
132012-56030	PIPE	10	900500-00005	NUT 5	20	P005-000010	STRAINER	26
132115-46730	GROMMET, FUEL	10	900502-00006	NUT 6 (3N)	18	P005-000100	SCREW, THROTTLEADJUST	26
145862-40630	SCREEN, MUFFLER	12	900518-00006	NUT, FLANGE	18	P005-000190	E-RING	26
156112-40630	GROMMET	6	900603-00005	WASHER 5	10	P005-000200	GASKET, METERING	26
159011-03432	COIL, SPARK PLUG	6	900702-00030	CIRCLIP 30	16	P005-000250	RETAINER	26
159012-03433	CAP, SPARK PLUG	6	910300-27700	WASHER,CIRCULAR 6	20	P005-000270	SCREW	26
162010-52830	LEAD, GROUND	6	91118-05020	BOLT	10	P005-000280	O-RING	26
175000-56831	CLUTCH ASSEMBLY	6	91118-05025	BOLT	16	P005-000510	DIAPHRAGM, PUMP	26
175005-44331	DRUM, CLUTCH	4	91118-05028	BOLT	4	P005-000520	GASKET, PUMP	26
175313-20430	RING, FELT	4	91121-04008	BOLT, FLANGE	12	P005-001000	ROLLER, GUIDE	26
177236-61830	SCREW	14	91363-04016	SCREW	4	P005-001240	POST	26
178003-52130	BRACKET SET, THROTTLE	18	91363-04016	SCREW	18	P005-001250	RETAINER,PLUG BALL	26
178012-52630	LOCKOUT, THROTTLE	18	91367-04010	SCREW	12	P005-001260	SCREW,MAINN MIXTURE	26
178013-52630	SPRING, THR. LOCK	18	94060-06200	BEARING BALL	16	P005-001270	PLUG, H AJUST SCREW	26
178043-42230	SPRING, THR. RETURN	18	94061-06200	BEARING, BALL	16	P005-001890	BASE, ASY PRIMER	26
210417-52730	BOLT, WING	8	94095-36201	BEARING BALL	2	P005-001900	SCREW	26
301200-29430	BAND ASSY	18	A011-000101	CRANKSHAFT,ASM	2	P005-002230	DIAPHRAGM ,METERING	26
610281-54131	COLLER	16	A021-003880	CARBURETOR, DIAPHRAGM	8	P005-002430	SPRING, MET. LEVER	26
610922-55931	HOLDER, MAIN PIPE	4	A021-003880	CARBURETOR, DIAPHRAGM	26	P005-002460	COVER ASY, ROTOR	26
660316-55630	CLIP	4	A051-001401	STARTER,RECOIL ASY	14	P021-007712	PISTON KIT	2
890152-04930	LABEL, CAUTION	16	A052-000180	PULLEY,ASM STARTER	14	P021-009461	CASE,ASM BEARING	16
890157-39130	LABEL, SWITCH	18	A101-000090	RING,PISTON	2	P021-009552	SHIELD KIT	20
890332-52730	LABEL, CHOKE	8	A130-002100	CYLINDER	2	P021-014550	BAND 25	18

NUMERICAL PARTS INDEX

Part No	Part description	Page	Part No	Part description	Page
P021-016090	FRONT HANDLE ASY	16	X698-000040	TOOL,CASE	24
P021-016642	MUFFLER ASY	12	X772-000840	MANUAL,OPERATOR	24
P021-035680	FUEL CAP ASY	10			
P021-038590	CASE,CLEANER ASY	8			
P022-002100	E-RING	14			
P022-006510	SPRING, RETURN	14			
P022-006850	PAWL, STARTER	14			
P022-008270	SPRING,DAMPER	14			
P022-019680	SPRING, SPIRAL	14			
P022-023170	GRIP, STARTER	14			
P022-025530	CASE	22			
P022-025560	BUTTON	22			
P022-025570	RETURN SPRING	22			
P022-025580	SET SCREW	22			
P022-025590	CORD GUIDE	22			
P022-025600	NYLON CORD	22			
P022-025630	COVER	22			
P022-025640	REEL	22			
P022-025660	SHAFT	22			
P022-025730	ROPE, STARTER	14			
P022-034030	PLATE, CAM	14			
P022-034040	DRUM, STARTER	14			
V103-001390	GASKET,INTAKE	8			
V103-001640	GASKET,INTAKE	8			
V104-000500	GASKET,EXHAUST	12			
V104-001760	GASKET,EXHAUST	12			
V150-000371	PLATE,EYE	12			
V202-000090	BOLT,4	4			
V202-000090	BOLT,4	14			
V315-000030	WASHER,CIRCULAR 30	4			
V430-002290	CABLE,BOWDEN	18			
V471-001190	PIPE	10			
V471-001200	PIPE	10			
V475-007300	TUBE	6			
V490-001240	CLIP	10			
V495-002690	BAND	18			
X047-000450	CUTTER,ASM LINE	22			
X505-000140	LABEL,CAUTION	16			
X505-002310	LABEL,CAUTION	4			
X530-000290	LABEL,EYE CATCHER	4			
X543-003870	LABEL,MODEL	4			
X543-003880	LABEL,MODEL	14			
X605-000100	TOOL,L WRENCH	24			
X606-000080	TOOL,BAR	24			
X690-000030	GOGGLE	24			